

# Patriot

*COBHAM*

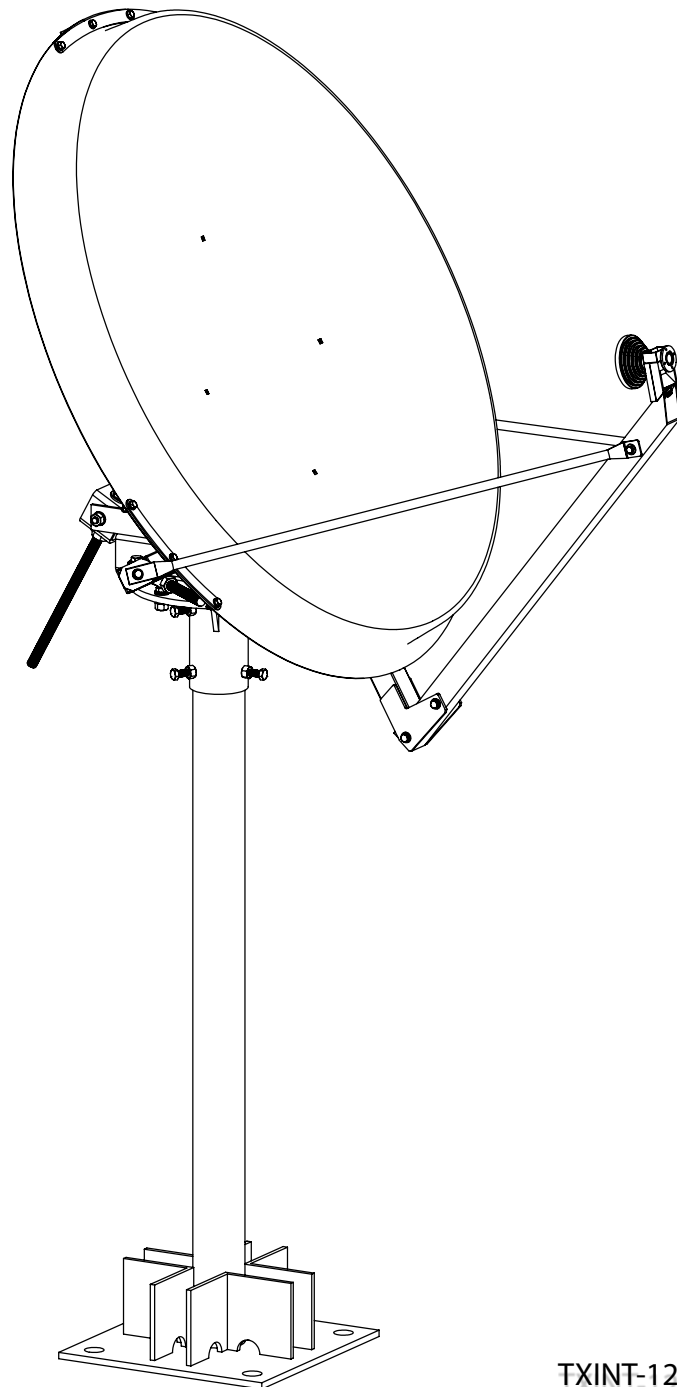

TXINT-120KUGHW  
1.2m HIGH WIND

# **COBHAM**

## LIMITED TWELVE (12) MONTH WARRANTY

This COBHAM Product is warranted to be free from defects in material and workmanship under normal use and service. COBHAM PLC shall repair or replace defective equipment, at no charge, or at its option, refund the purchase price, if the equipment is returned to PATRIOT ANTENNA not more than twelve (12) months after shipment. Removal or reinstallation of equipment and its transportation shall not be at cost of PATRIOT ANTENNA except PATRIOT ANTENNA shall return repaired or replaced equipment freight prepaid.

This Warranty shall not apply to equipment which has been repaired or altered in any way so as to affect its stability or durability, or which has been subject to misuse, negligence or accident. This Warranty does not cover equipment which has been impaired by severe weather conditions such as excessive wind, ice, storms, lightning, or other natural occurrences over which COBHAM PLC has no control, and this Warranty shall not apply to equipment which has been operated or installed other than in accordance with the instructions furnished by PATRIOT ANTENNA.

Claimants under this Warranty shall present their claims along with the defective equipment to PATRIOT ANTENNA immediately upon failure. Noncompliance with any part of this claim procedure may invalidate this warranty in whole or in part.

THIS WARRANTY IS EXPRESSLY IN LIEU OF ALL OTHER AGREEMENTS AND WARRANTIES, ANY IMPLIED WARRANTY OF MERCHANTABILITY OR FITNESS FOR A PARTICULAR PURPOSE IS LIMITED IN DURATION TO THE DURATION OF THIS WARRANTY. PATRIOT ANTENNA DOES NOT AUTHORIZE ANY PERSON TO ASSUME FOR IT THE OBLIGATIONS CONTAINED IN THIS WARRANTY AND PATRIOT ANTENNA NEITHER ASSUMES NOR AUTHORIZES ANY REPRESENTATIVE OR OTHER PERSON TO ASSUME FOR IT ANY OTHER LIABILITY IN CONNECTION WITH THE EQUIPMENT DELIVERED OR PROVIDED.

IN NO EVENT SHALL COBHAM PLC OR PATRIOT ANTENNA SYSTEMS BE LIABLE FOR ANY LOSS OF PROFITS, LOSS OF USE, INTERRUPTION OF BUSINESS, OR INDIRECT, SPECIAL OR CONSEQUENTIAL DAMAGES OF ANY KIND.

In no event shall COBHAM PLC or PATRIOT ANTENNA be liable for damages in an amount greater than the purchase price of the equipment.

Some states do not allow limitations on how long an implied warranty lasts, or allow the exclusion or limitation of incidental or consequential damages, so the above limitations or exclusions may not apply to you.

PATRIOT ANTENNA has the right to void the warranty when the antenna is installed by someone other than a certified installer.

Product Serial Number- \_\_\_\_\_

Date Purchased- \_\_\_\_\_

Patriot Antenna Systems

704 North Clark Street

Albion, MI 49224 USA

Tel: (517)629-5990

Fax: (517)629-6690

E-mail: [info@sepatriot.com](mailto:info@sepatriot.com)

## IMPORTANT!!!

INSTALLATION OF THIS PRODUCT SHOULD BE PERFORMED ONLY BY A PROFESSIONAL INSTALLER AND IS NOT RECOMMENDED FOR CONSUMER D.I.Y. (DO-IT-YOURSELF) INSTALLATIONS.

### WATCH FOR WIRES!

Installation of this product near power lines is dangerous. For your own safety, follow these important safety rules.

1. Perform as many functions as possible on the ground.
2. Watch out for overhead power lines. Check the distance to the power lines before starting installation. We recommend you stay a minimum of 6 meters (20 feet) from all power lines.
3. Do not use metal ladders.
4. Do not install antenna or mast assembly on a windy day.
5. If you start to drop antenna or mast assembly, get away from it and let it fall.
6. If any part of the antenna or mast assembly comes in contact with a power line, call your local power company. DO NOT TRY TO REMOVE IT YOURSELF! They will remove it safely.
7. Make sure that the mast assembly is properly grounded.

### WARNING

Assembling dish antennas on windy days can be dangerous. Because of the antenna surface, even slight winds create strong forces. For example, a 1.0m antenna facing a wind of 32 km/h (20 mph) can undergo forces of 269 N (60 lbs.). Be prepared to safely handle these forces at unexpected moments. Do not attempt to assemble, move or mount dish on windy days or serious, even fatal accidents may occur. PATRIOT ANTENNA SYSTEMS is not responsible or liable for damage or injury resulting from antenna installations.

### WARNING

Antennas improperly installed or installed to an inadequate structure are very susceptible to wind damage. This damage can be very serious or even life threatening. The owner and installer assumes full responsibility that the installation is structurally sound to support all loads (weight, wind & ice) and properly sealed against leaks. PATRIOT ANTENNA SYSTEMS will not accept liability for any damage caused by a satellite system due to the many unknown variable applications.

## Introduction

Thank you for purchasing your Patriot Commercial Antenna. We trust that you will find this to be a well designed product that will provide many years of reliable service. Please read this manual thoroughly before beginning assembly. For best results in the assembly process, perform each step in the same sequence as listed in this manual. Record the serial number of the unit on to page two for future reference and read the warranty information. The serial number plate can be found on the pedestal mount.

## Unpacking and Inspection

Shipping cartons should be unpacked and contents checked for damaged or missing parts. Should there be any parts that are damaged or missing, please contact technical support for replacement.

## Site Selection

The main objective of conducting a site survey utilizing a compass and inclinometer is to choose a mounting location on the ground that will give you the greatest amount of swing for azimuth and elevation for present as well as future use. A thorough pre-installation site survey is strongly recommended because it can alert you to any "look angle", soil, wind or other problems.

The first and most important consideration when choosing a prospective antenna site is whether or not the area can provide an acceptable "look angle" to the satellite. A site with a clear, unobstructed view facing south, southeast is required. Your antenna site must be selected in advance so that you will be able to receive the strongest signal available. Also consider obstructions that may occur in the future such as the growth of trees.

It is important to conduct an on-site survey with a portable antenna or with a compass and clinometer to avoid interference, obstructions, etc.

When selecting "look angle", be sure to observe and take readings approximately 10 deg to the left and right, above and below your selected "look angle".

Before Ground Pole Installation, the soil type should be checked because soil conditions vary widely in composition and load bearing capacity. A soil check will help you to determine the type and size of foundation required to provide a stable base for the antenna.

Before digging is done, information regarding the possibility of underground telephone lines, power lines, storm drains, etc., in the excavation area should be obtained from the appropriate agency.

As with any other type of construction, a local building permit may be required before installing an antenna. It is the property owner's responsibility to obtain any and all permits. Ground mounts are certified for 125 mph wind survival.

ITEM NO.	PART NUMBER	DESCRIPTION	QTY.
1	2180H0002	TOP MOUNT ASSY	1
2	2180H0001	1.8M AZ-EL ASSEMBLY	1
3	218008	ASSY, 1.8M TX AZ ADJUST ROD PLATED	1
4	231104G	BLOCK, 3.1 PIVOT	1
5	218005	ASSY, 1.8M TX ELEV ROD PLATED	1
6	218006	ASSY, 1.8TX CLEVIS PLATED	1
7	2120H0010	BACK FRAME ASSY, 1.2M HIGH WIND	1
8	TXFD-KUL	FEEDHORN, KU ASSEM W/HOLDER	1
9	2120H0008	FEED BOOM, 1.2m HIGH WIND	1
10	2120H0006	STRUT, 1.2m HIGH WIND ASSEM, 1.2m REF. WITH REINFORC. BRACKETS	2
11	212001HW		1

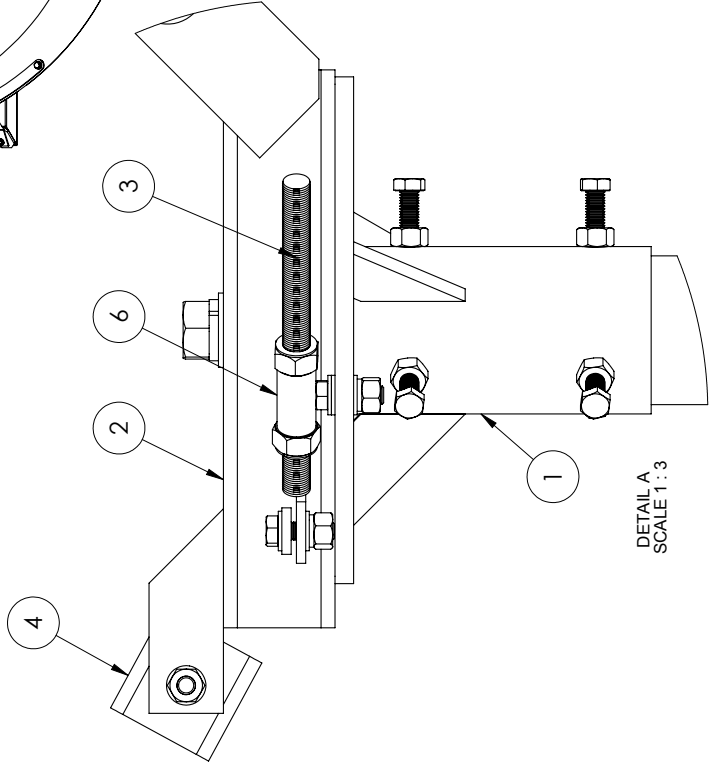
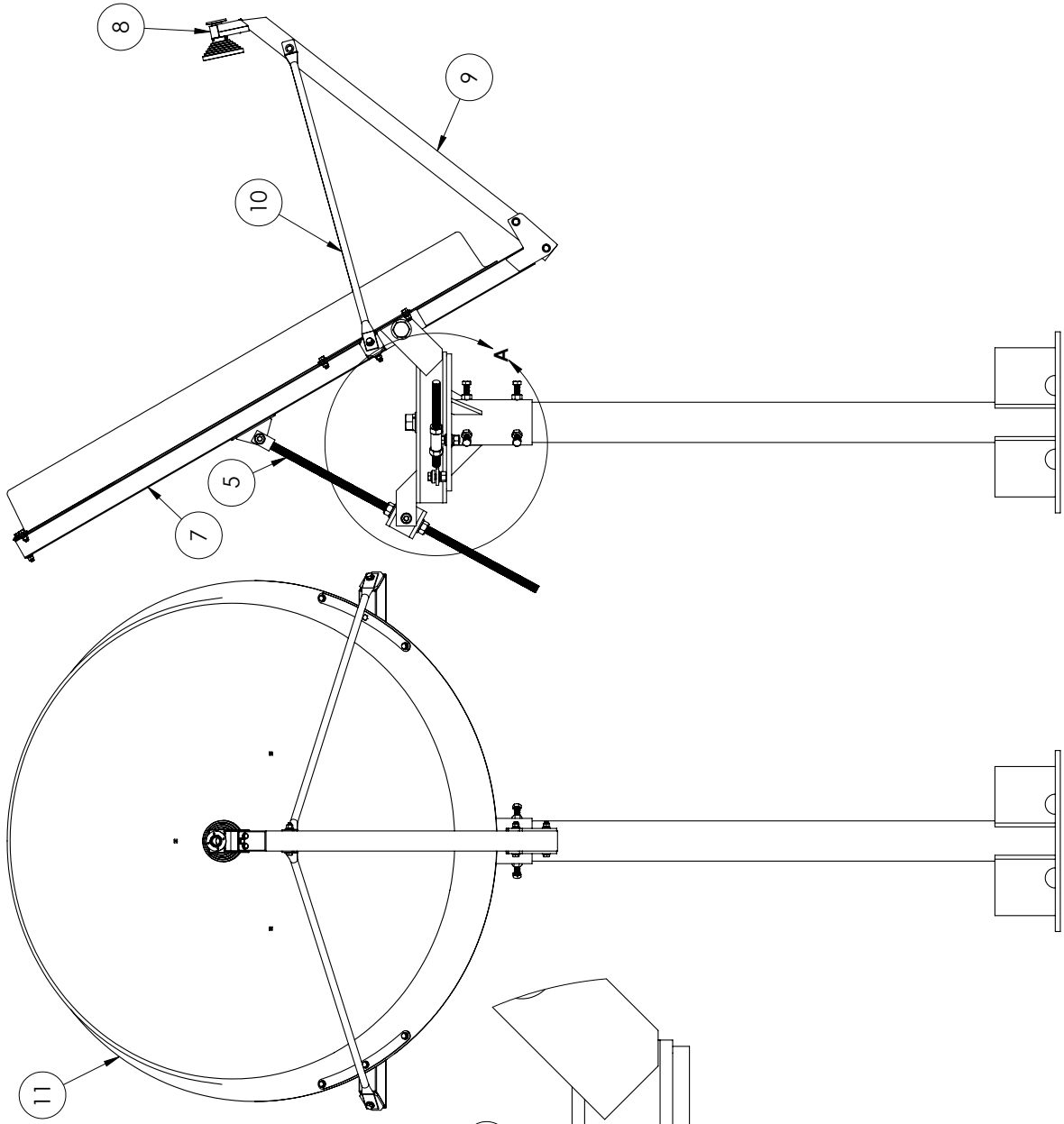

DETAIL A  
SCALE 1:3

# Top Mount Attachment

- 1) Attach Top Mount Assembly (2180H0002) to pipe assembly as pictured.
- 2) Do not tighten bolts at this time, as there maybe adjustments needed later.  
(Take note of front of assembly and place accordingly )

Front Edge

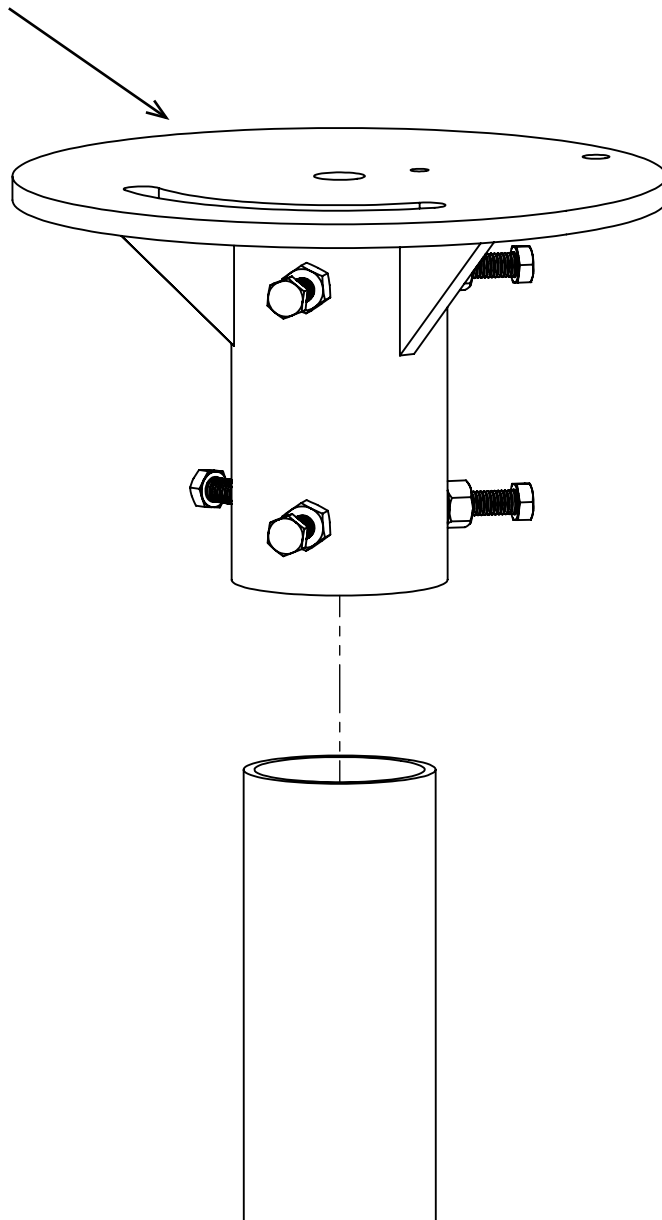

# AzEl Mount and Adjustment Attachment

- 1) Attach Az-El mount assembly (2180H0001) to Top Mount Assembly (2180H0002) as pictured.
- 2) Attach Azimuth Adjustment Rod (218008) as pictured
- 3) Do not tighten bolts at this time, as there may be adjustments needed later.

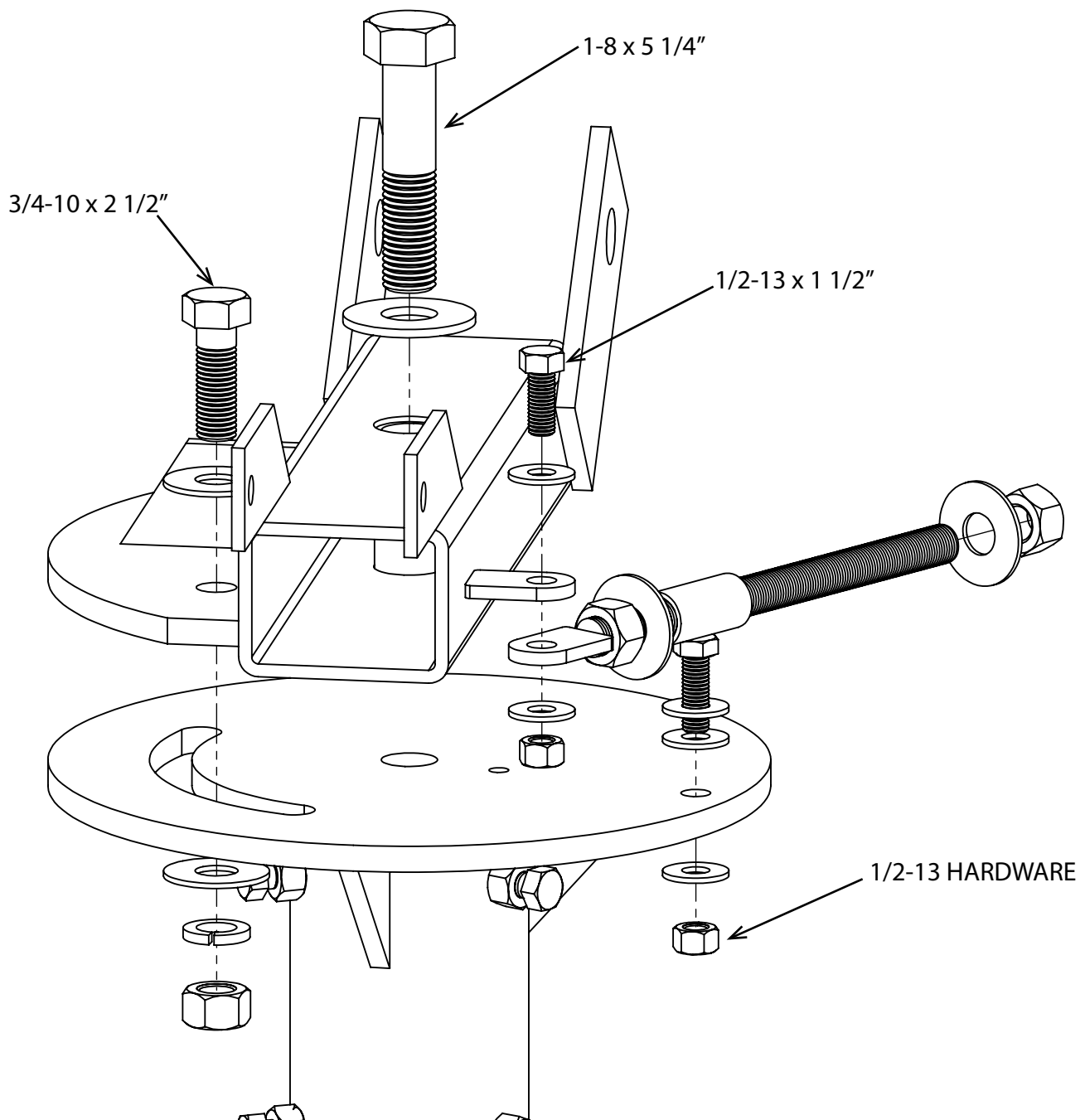

# Elevation Block Attachment

- 1) Attach Elevation Pivot Block (231104g) to the Az-El mount Assembly (2180H0001) as pictured.
- 2) Do not tighten bolts at this time, as there maybe adjustments needed later.

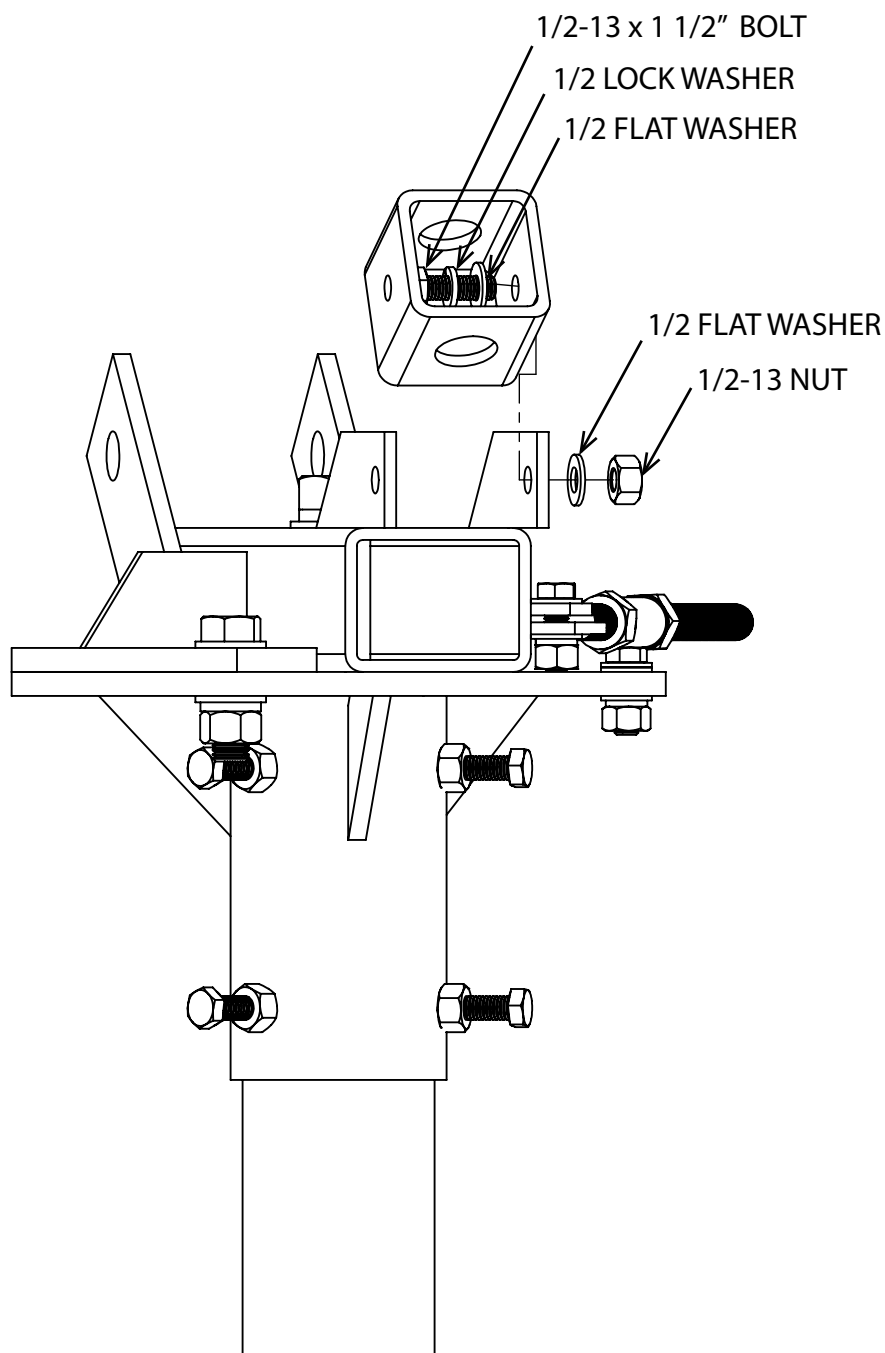

# Back Structure Attachment

- 1) Attach the Back Frame Assembly (2120H0010) to Az-El mount Assembly (2180H0001) as pictured.
- 2) Do not tighten bolts at this time, as there maybe adjustments needed later.

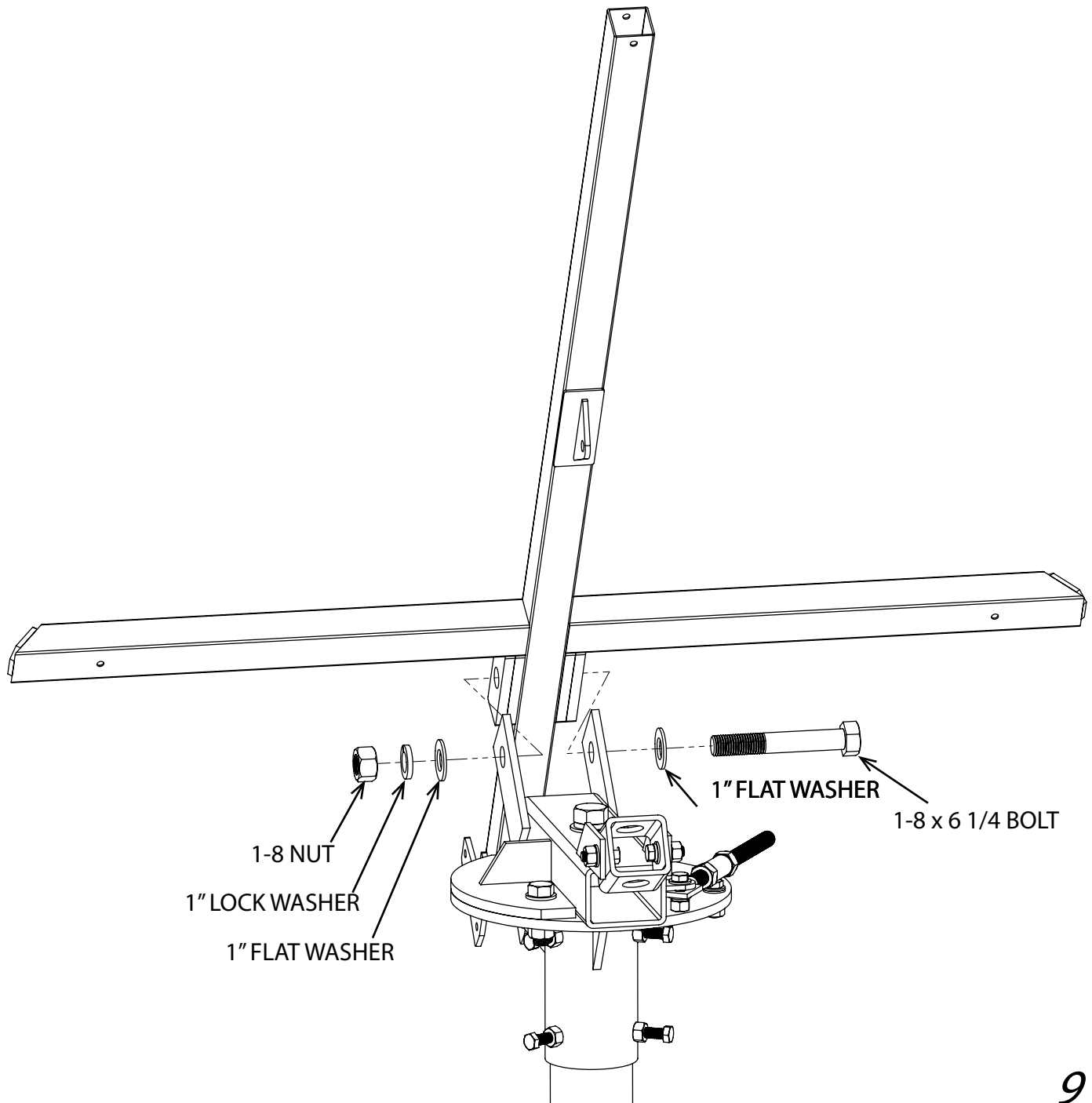

# Elevation Rod Attachment

- 1) Attach the Elevation Adjustment Rod Assembly (218005) to the Back Frame Assembly (2120H0010) and Elevation Block (231104g) as pictured.
- 2) Do not tighten bolts at this time, as there maybe adjustments needed later.

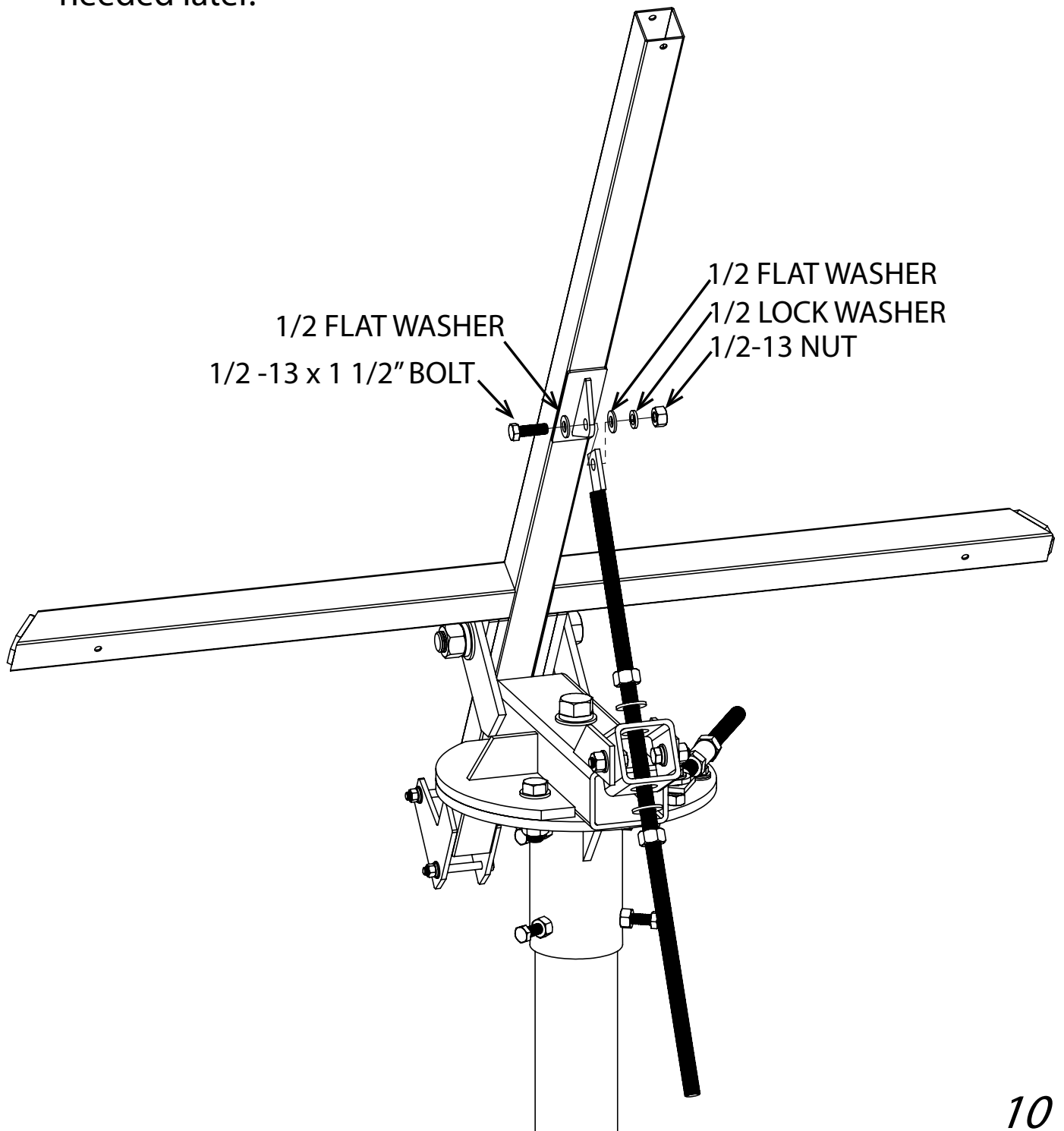

# Reflector Assembly Attachment

- 1) Attach the Reflector Assembly (212001HW) to the Back Frame Assembly (2120H0010) as pictured.
- 2) Tighten these bolts at this time

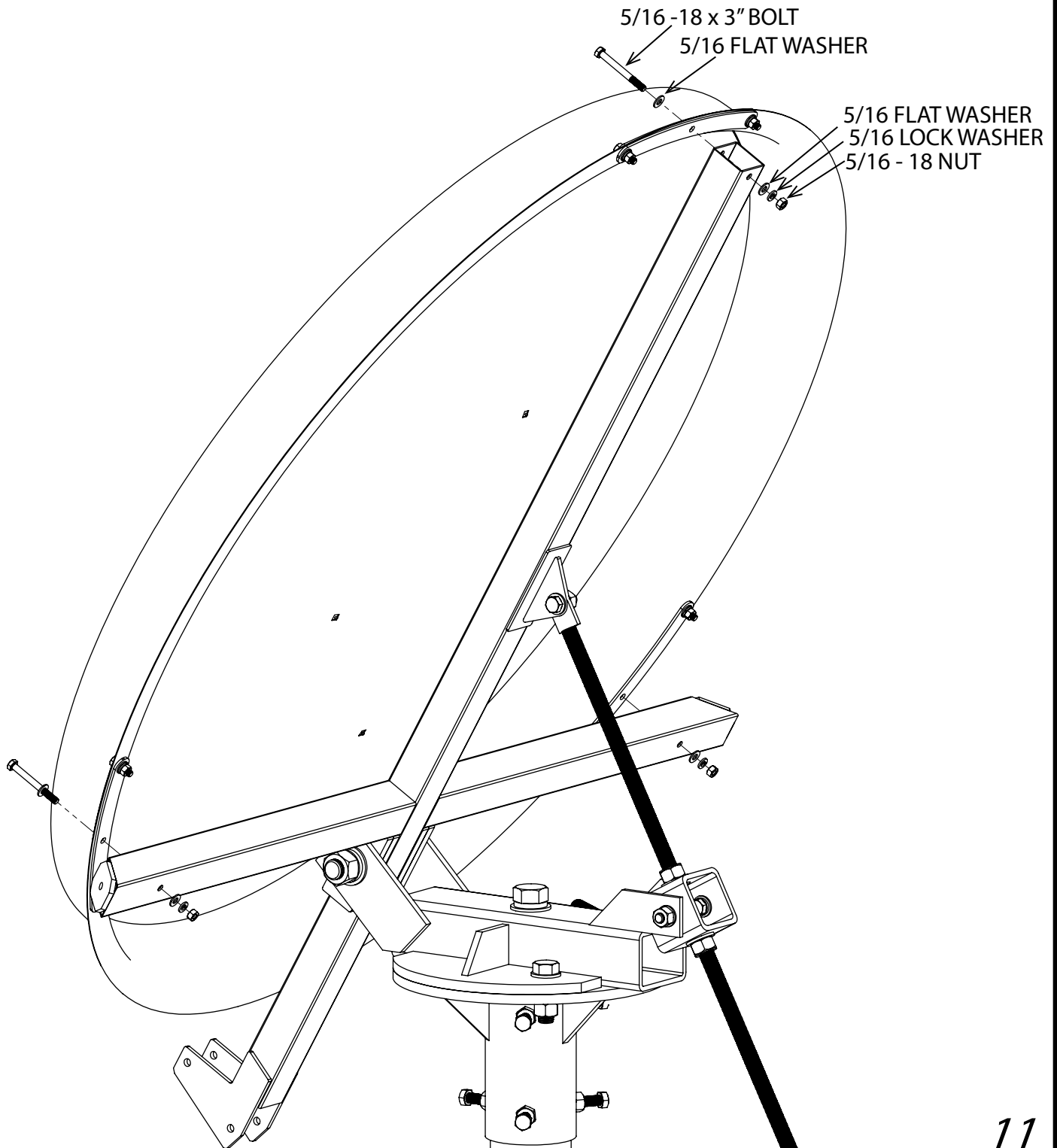

# Feed Boom Attachment

- 1) Attach the Feed Boom (2120H0008) to the Back Frame Assembly (2120H0010) as pictured.
- 2) Tighten these bolts at this time

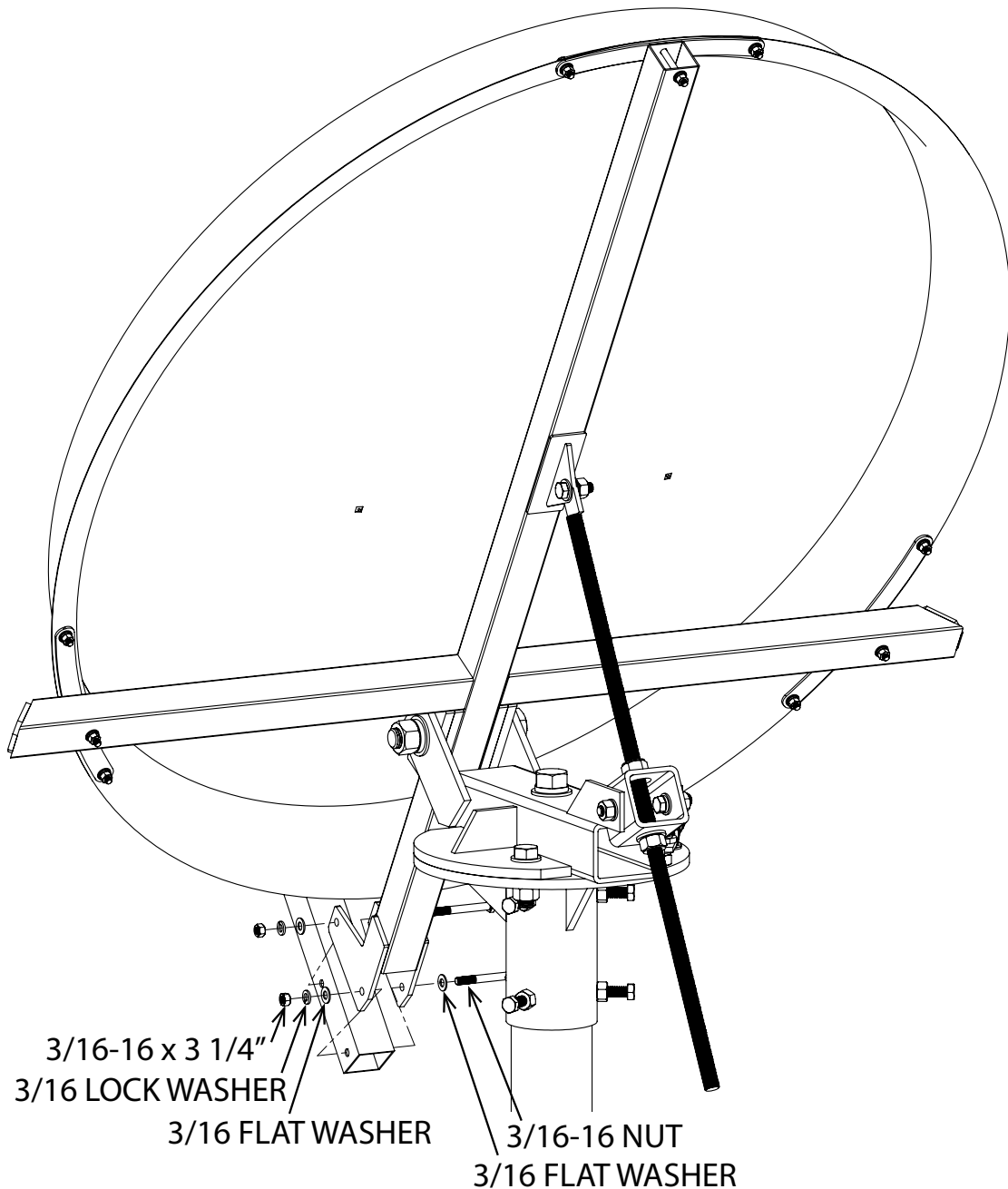

# Feed Boom Struts Attachment

- 1) Attach the Feed Boom Struts (2120H0006) to the Feed Boom (2120H0008) and Reflector Assembly (2120001HW) as pictured.
- 2) Tighten these bolts at this time.
- 3) Once proper angles have been found (both Azimuth and Elevation) tighten all hardware.

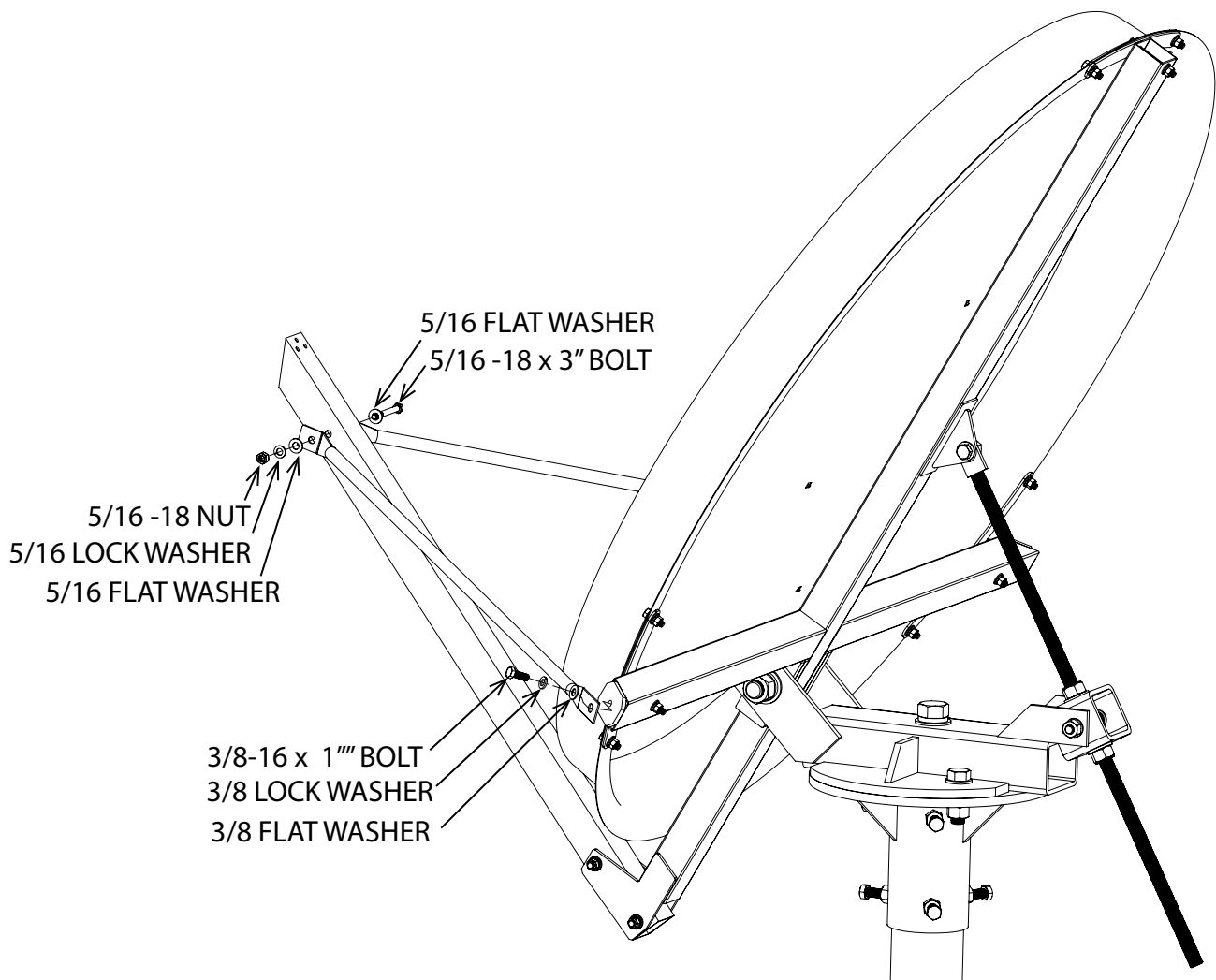

## Grounding

### Grounding Antenna Feed Cables

1. Ground antenna feed cables in accordance with current National Electric code and local electric codes. The illustration shows a typical grounding method.

Clamps that provide a solid connection between ground wire and a ground source should be used.

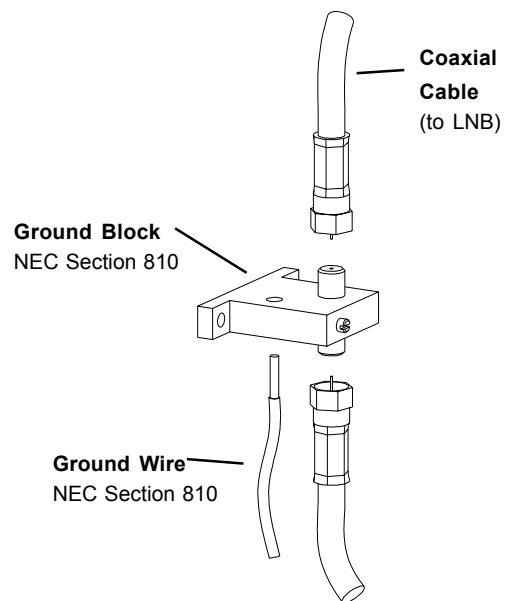

### Grounding Non-Penetrating Mount Frame (if applicable)

1. Ground the Non-Penetrating mount frame. The illustration shows a typical grounding method.

Refer to the NEC Section 810 and local electric codes for specific instructions on grounding the remaining end of the ground wire.

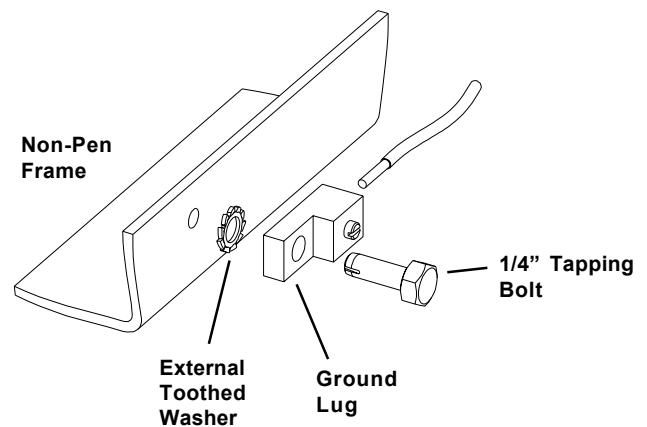

### Antenna Pointing

- 1) Begin by obtaining the correct Az/EI pointing data for the satellite of interest based for your site location.
- 2) Using an inclinometer or position readout form controller placed on the enclosure drum surface, position the antenna to the specified elevation angle.
- 3) Manually scan the antenna (back-and-forth in the azimuth around the direction of the specified azimuth angle) to achieve the maximum transponder signal.
- 4) Next repeat the procedure for elevation.
- 5) Repeat this procedure alternating between the azimuth and elevation until maximum transponder signal is achieved.

### Feed Adjustment (Polarity tuning)

1. Adjust the Feed to the appropriate skew angle using the provided scale reference.

NOTE: Refer to the chart on back for polarization angle. Elevation and polarity are both dependent on site azimuth and the difference between satellite and site longitude.

NOTE: Some satellites have a slant angle with respect to the satellite belt angle. Contact the satellite operator for details.

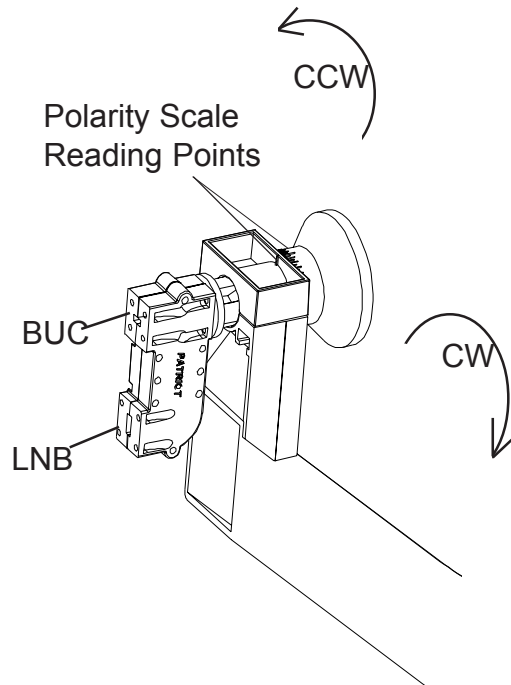

### Feed Rotation Chart

Install site west of satellite	Install site East of satellite	
CW	CCW	Northern Hemisphere
CCW	CW	Southern Hemisphere

### Feed Assembly

1. Attach the relevant Feed Assembly.
2. Insert the Feed Assembly into the Feed holder and assemble to the Feed Support Tube using the hardware illustrated below.
3. Insert the Feed Support Tube into the support tube.

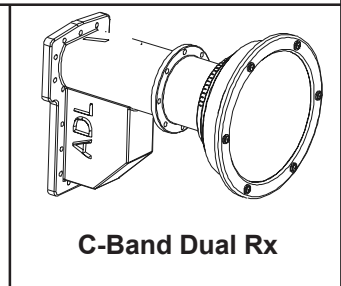
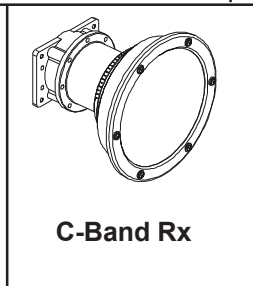
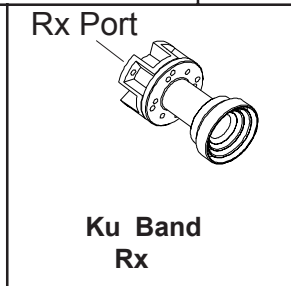
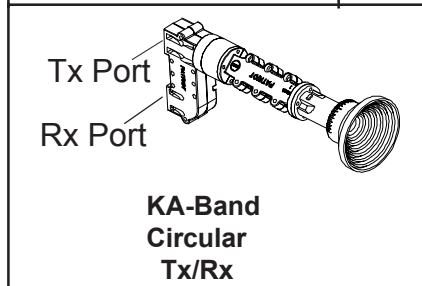
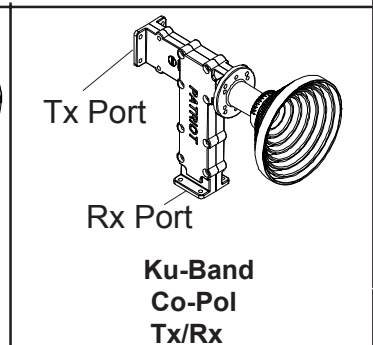
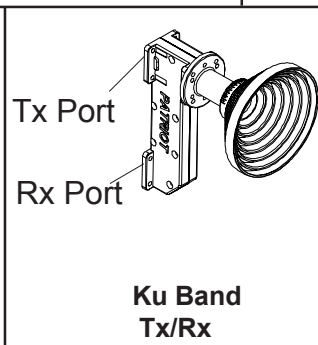
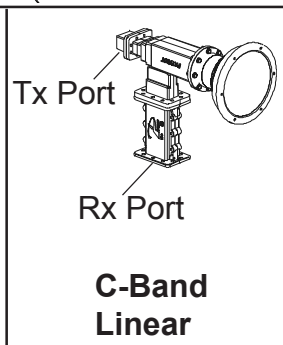
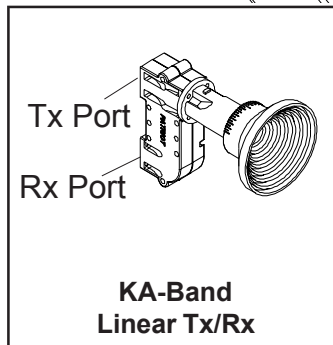
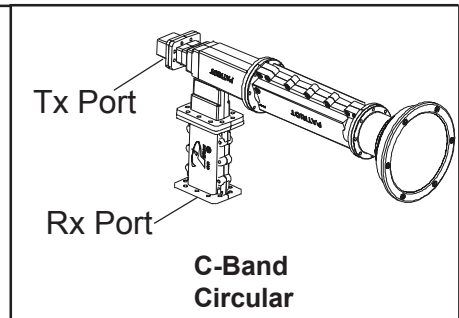
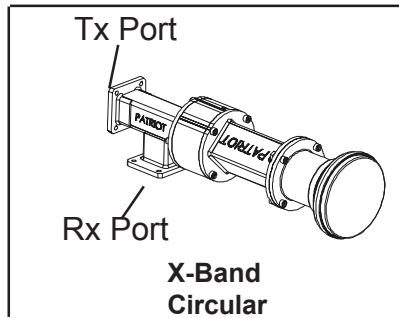
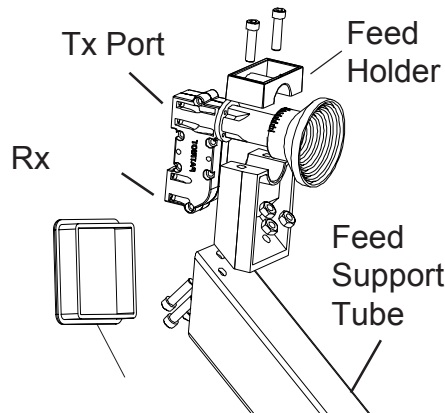

# Polarization Chart

$$\text{Delta Longitude} = |\text{LONG}_{\text{sat}} - \text{LONG}_{\text{site}}|$$

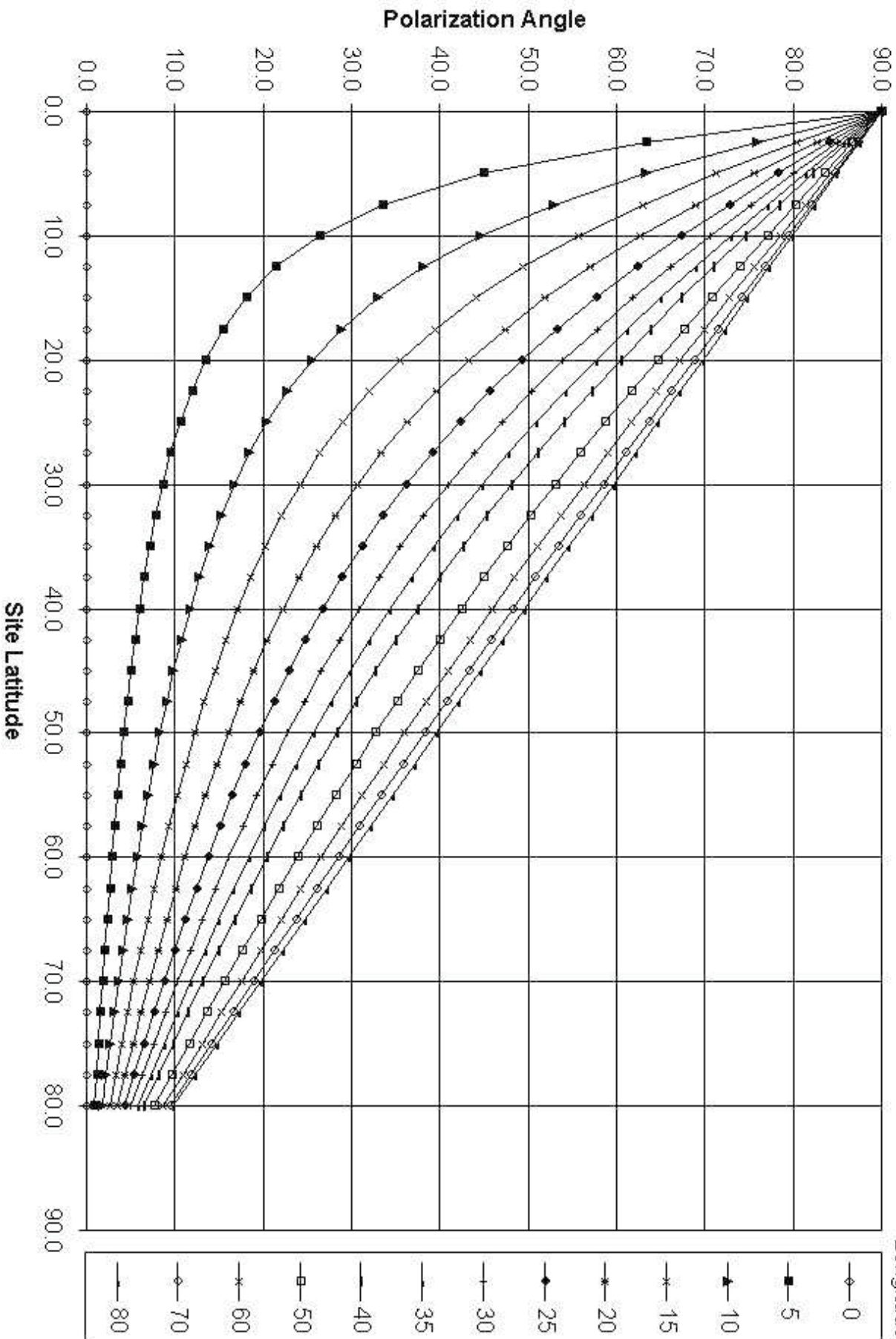

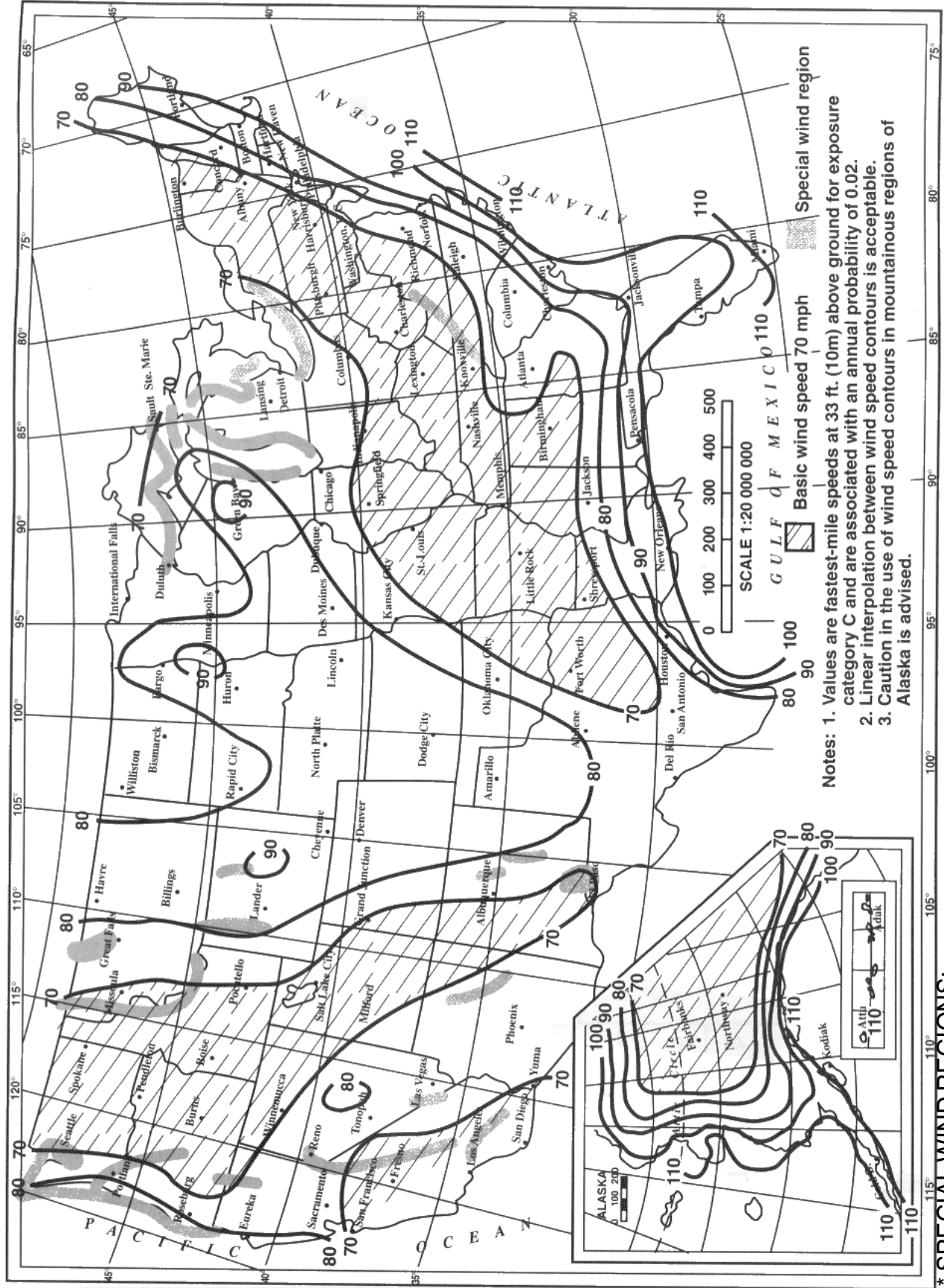

Notes: 1. Values are fastest-mile speeds at 33 ft. (10m) above ground for exposure category C and are associated with an annual probability of 0.02.  
 2. Linear interpolation between wind speed contours is acceptable.  
 3. Caution in the use of wind speed contours in mountainous regions of Alaska is advised.

**\* SPECIAL WIND REGIONS:**

Records or experience indicates that the wind speeds are higher in mountainous terrain, gorges, and ocean promontories and shall be examined for unusual wind conditions. Contact your local meteorological authority and a local civil or professional engineer if your installation is in one of these areas.

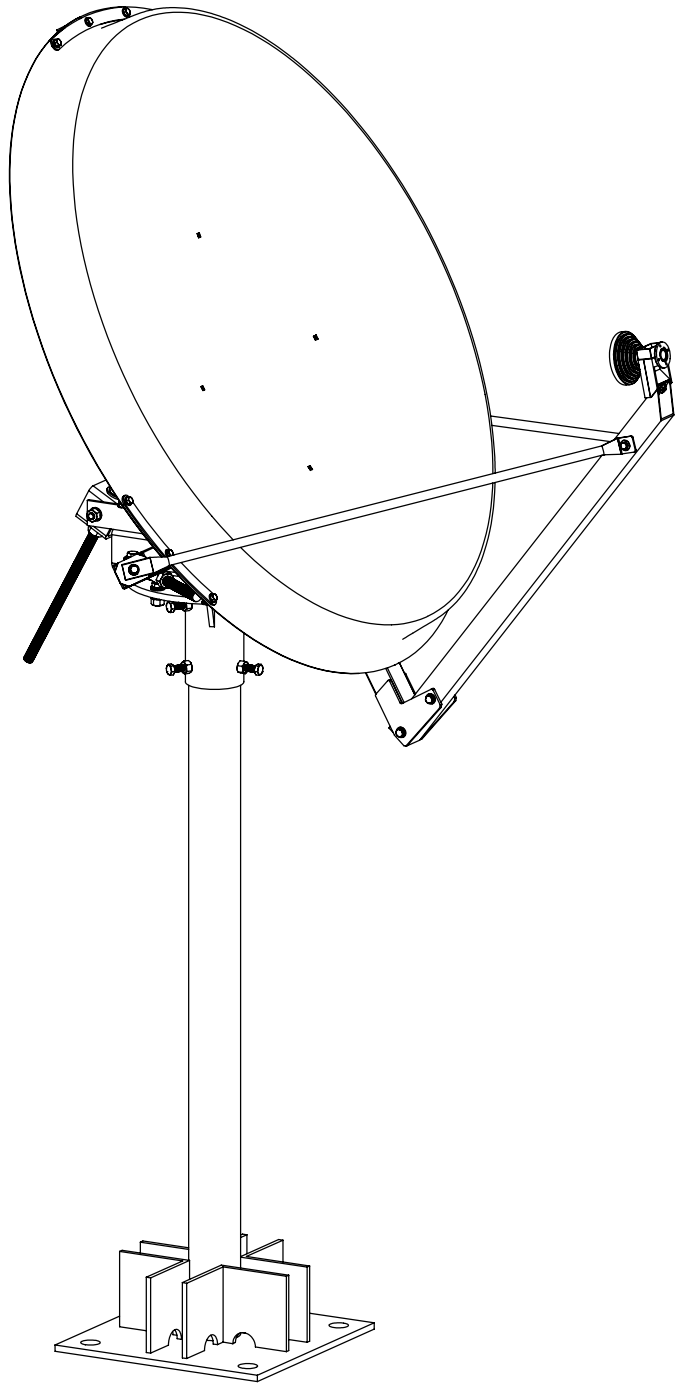

**Patriot**  
*COBHAM*

*PATRIOT ANTENNA SYSTEMS  
704 NORTH CLARK STREET  
ALBION, MICHIGAN 49224 USA  
WWW.SEPATRIOT.COM*